

GLAZINGVISION

Installation Manual

Pitchvent



Contents

Section Description	Page
Introduction	3
Safety Information	4
Pre-Installation Preparation	6
Preparation of the Roof	8
Installation Procedure	11
Chain Actuated Pitchvent Setup	21
Manual Crank Pitchvent Setup	22
Interior Finishing	25

Introduction

Thank you for purchasing a Glazing Vision Pitchvent. In order to ensure that it gives you many years of service it is important that before commencing any work you read these instructions fully and ensure that they are strictly followed for a successful and trouble free installation.

We recommend that the installation should be undertaken by your roofing contractor, Glazing Vision recommends a licensed/registered contractor in good standing. This will ensure a reliable product and enable the property owner to benefit from a 5 year warranty on the product. It should be noted that an installation by non-approved installers will result in a reduced warranty period of just 2 years.

By following the correct installation procedure, a reliable and high performing end result is guaranteed. The critical operations that can lead to problems if not done correctly are the lifting, preparation of the supporting structure, and ensuring that the product is mounted on the correct pitch with the hinge on the high side. Taking the time to carry out these operations correctly will ensure that the product does not twist or distort and allow the installed product to move freely and unimpeded with minimum load on the chain actuators and no undue stresses in the frame or glass.



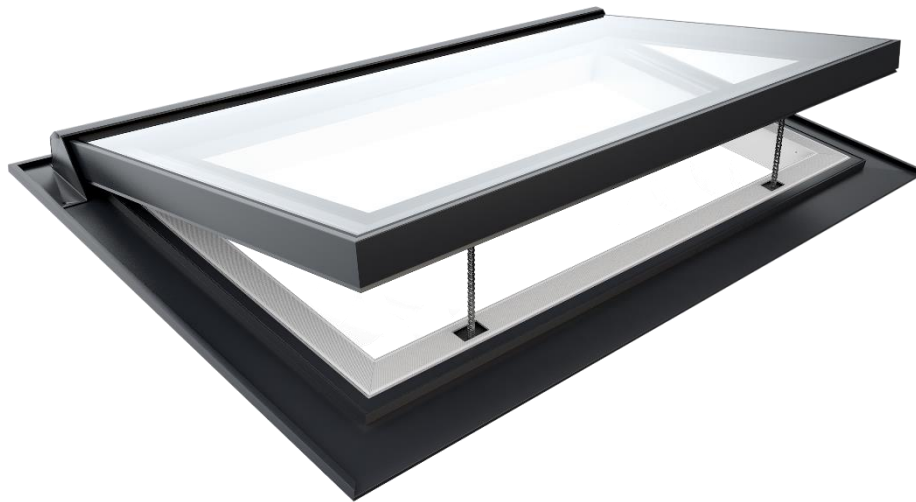

Care should be taken when working on the product, avoiding accidental damage and ensuring operational reliability.

Should you have any queries beyond this manual please do not hesitate to contact Glazing Vision.



Safety Information

Installation of your roof window may involve working at heights, working at an unusual angle, being in unfamiliar locations or all of these. **Before** work is commenced, stop and consider the best way to carry out the task and what hazards you might encounter.

	<p>These products can be very heavy. Extreme care must be taken during handling and installation. Full consideration should be given to how you will safely transport your roof window product from the delivery vehicle to the installation location. Glazing Vision strongly recommends that specialist, mechanical lifting equipment is employed.</p>
	<p>Consider:</p> <ul style="list-style-type: none"> • The weight(s) of the product purchased. • How you will safely transport your roof window product from the delivery vehicle to the installation location. • All lifting methods and equipment required for safe installation to eliminate manual handling. • How you will safely access the area to carry out installation. • Any openings, voids or unprotected edges that might pose a significant risk whilst working at height. • Use of scaffolding with all appropriate edging, rails and inspection certification. • If specialist access or equipment is required e.g. a fall arrest system. • What personal protective safety equipment (PPE) is required for working at height – e.g. harness. • Methods for safe working, for example, to avoid falling from height, reducing manual handling and so as not to drop equipment. • How you will transport tools and other equipment to the installation area. • The number of persons required to assist with safe installation. • The competence, capability and experience of the installation team to safely carry out the task. • Impact of weather on safe installation, especially driving rain and high winds. <p>If in doubt, please contact Glazing Vision for assistance.</p>
	<p>Anticipated hazards may include:</p> <ul style="list-style-type: none"> • Falls from height • Working with specialist lifting equipment or third-party lifting • Manual handling injury • Equipment falling from height • Slips, trips and falls • Fragile roof areas. • Finger or clothing entrapment under unit, in mechanical or moving parts • Working with electricity • Impact of weather conditions • Competence of personnel
	<p>Do not attempt to repair, move or dismantle the product unless suitably competent and qualified to do so, with the appropriate safety measures in place. Any repairs and/or movement of the product may invalidate the warranty. Please seek advice from Glazing Vision.</p>
	<p>Any electrical work is to be carried out by a qualified and competent electrician in accordance with Glazing Vision’s wiring diagram(s).</p>



Warning

The following warnings are here to prevent personal injury and damage to the product. Please follow them explicitly.

General:

- The product must be properly installed and commissioned in accordance with this manual before it is used.
- Glazing Vision strongly recommends that any work is carried out by suitably qualified individuals (e.g. licensed/registered contractors, Glazing Vision Engineers or Approved Installers, or an experienced electro-mechanical service engineer).
- Glazing Vision strongly recommends that specialist, mechanical lifting equipment is employed.
- Use the product only for its intended purpose.
- Regular cleaning and maintenance must be carried out according to guidelines.
- A safe working platform must be provided for any installation/maintenance work carried out. This includes suitable edge protection.
- Glazing Vision cannot be held responsible for damage incurred during the lifting and transportation of the product to the installation location (please refer to terms and conditions of sale).

Pre-Installation:

- Glazing Vision products are heavy, fragile and of awkward shape and size. There may be uneven weight distribution due to the materials used and their design.
- The weight(s) of each individual product (or product section) will be clearly marked on the product and will be communicated to clients before dispatch of goods.
- Never install any product showing signs of damage. If in doubt consult Glazing Vision for advice.
- Please dispose of the packaging material for this product in a considerate manner. Cardboard and wood items are widely recycled.

Electrical Works/Cables:

- It is recommended that electrical work is carried out by a qualified and competent electrician.
- Do not pull, squash, bend or damage cables where they exit the product. Doing so may loosen connections and this may result in damage to the product and/or create the need for a repair visit.
- Should any cables or electrical components break or become damaged, have them repaired or replaced immediately. Deteriorated insulation of electrical parts or overloading may cause an electric shock or fire.
- Do not install the circuitry in a damp place or a place where it may come into contact with water.

During Use:

- Do not touch the chain actuators after operating the unit as they may become hot.
- Do not walk or sit on the unit.
- Risk of crush and/or trapping injuries. Make sure that fingers and other obstructions are kept clear of the product and its mechanisms at all times.
- Overcurrent protection is designed to prevent damage to the product and its mechanisms. It should not be relied upon to prevent injuries.
- Do not place anything on, or cause obstruction to, the moving sections of the product as this may cause damage to the mechanisms/product and/or prevent the unit from opening/closing.
- Do not allow unauthorized persons (e.g. children) to operate the product as this may lead to personal injury or damage to the product. Do not leave children or pets unsupervised near the product – it may open/close unexpectedly (e.g. due to the rain sensor activating) and cause injury.
- Do not leave the product open in the rain, this could damage the control board and/or mechanisms. If required, a rain sensor can be specified at the time of order.

For more information or assistance please contact Glazing Vision.

Pre-Installation Preparation



These products can be very heavy. Due consideration should be given to getting the product onto the roof safely and extreme care taken during installation.

Points to Note Prior to Commencing Installation

1. The Pitchvent should arrive on site in undamaged packaging, which includes a wooden build frame/blocks, cardboard, polyfoam glass protection and low tack tape. Please inspect for damage to packaging and/or product and advise Glazing Vision of any damage or shortfall within 48 hours from signing the receipt of your delivery.
2. Enclosed within the box containing this manual will be the required number of fixing woodscrews and a number of plastic packers, as well as some silicone and other required materials. The installation kit is supplied with a control switch (Chain Actuated Pitchvents only), a Power Supply Unit (PSU – Chain Actuated Pitchvents only) and any additional optional items selected at the time of order.

Standard Installation Hardware

Enclosed within the hardware box for each unit you should find at least the following:

Stainless steel woodscrews



Plastic horseshoe packers

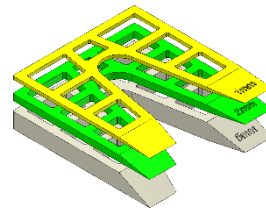

(various sizes)

Low modulus silicone



Butyl tape



(1/4" diameter)

Flashing Kit

If a flashing kit has been specified, the following items should also be included:

Lead sheet



Head flashing (5-7/8" wide)
Sill flashing (17-3/4" wide)
Lead for soakers (17-3/4" wide)

Roofing underlay



Head apron (39-3/8" wide)
Jamb aprons (39-3/8" wide)

Butyl tape

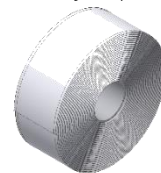

(2" wide)

3. Chain Actuated Pitchvents have two coiled cables emerging from the motor housing as standard (if optional extras have been selected, other cables may also be present). This includes 2 single cores (red and black) 24V DC power cables and a 6 core control cable. These cables will have identification labels on them (labels should not be removed until final installation). Please refer to Glazing Vision's wiring diagrams for details of wiring requirements. Only the supplied PSU can be fitted to the unit, failure to connect this unit or wiring direct to the main power supply will invalidate the product warranty.

4. The switch used to control the operation of the Chain Actuated Pitchvent is a two button wall mounted control switch. This switch will allow you to operate and stop at any position between the fully open and closed positions. This switch also contains a tri-color LED to display the product status to the user. The correct control switch is supplied in the installation kit and must be installed to avoid invalidating the warranty. If required, this switch can be installed in a maintenance area and another switch of a retractive single pole double throw (SPDT, 'on-off-on', latching off) type can be parallel wired for regular use. Using a SPDT switch that only latches 'on-on' can seize the control board and therefore should not be used.
5. The Chain Actuated Pitchvent also requires a 5A fused double pole single throw (DPST) type switch (not supplied). Combined with disconnecting the battery backup (if specified), installing this switch as per the wiring diagram will allow the control board to be reset in the event of a fault (for more information on faults and troubleshooting see the operation and maintenance manual).
6. The supporting structure must already be in place for the product. The dimensioning of the product will have taken into consideration the dimensions of the supporting structure including all weathering. More information about supporting structure construction can be found in Glazing Vision's sales drawings. **Please note that a minimum distance of 4" clearance between the supporting structure and any surrounding structures must be left on all sides. Sufficient room for installation (including weathering) and maintenance must also be allowed for.**
7. It is important to consider the type of tile or other roof finish to be used. The opening in the roof should ideally be positioned so that you get a full tile at the top and at the bottom of the product, avoiding the need to cut tiles down.
8. It is important to ensure that the area of installation is suitably prepared. The area surrounding the supporting structure should be clear to provide safe access during the installation works. It will be necessary to work on the outside and therefore suitable provisions should be made for safe handling of the product, including all relevant personal protective equipment (PPE) and safety systems for working at heights.
9. Before starting installation, Glazing Vision advises that the physical supporting structure dimensions are cross-checked with those given for the order, to ensure the product will fit. The supporting structure will need to be within $\pm 3/8$ " of the ordered size (measured across the flats). The top surface of the supporting structure should be flat without undulations greater than $\pm 1/16$ ". Also check the diagonals to ensure that the supporting structure has been constructed square. The supporting structure must be weathered as per the sales drawings. **If using any metallic waterproofing material, take care when applying it to the product/supporting structure, as if done incorrectly it can cause a thermal bridge which can lead to internal condensation and invalidate the product warranty.**



It is important that the supporting structure is made to the pitch specified on the order confirmation. Failure to comply with this may result in product failure due to the overloading of its mechanisms. Glazing Vision accepts no responsibility for failures as a result of incorrectly pitched products.

10. These products can be very heavy. Glazing Vision strongly recommends that a structural engineer is consulted when designing the structure(s) that will support the product and the surrounding structure. **Nothing in this manual or on Glazing Vision's sales drawings constitutes a structural proposal.**
11. Preparation of the roof prior to installation will vary depending on roof type and roofing materials. A few common scenarios are included in this manual. Please follow the applicable steps for your configuration. Glazing Vision strongly recommends that a 'dry run' (without any silicone or butyl) is completed before committing to the final installation.

Sales Drawings

Sales drawings for the Pitchvent can be obtained by downloading them from Glazing Vision's website (www.glazingvision.com/technical-downloads) or by contacting Glazing Vision.



Sales drawings should accompany this installation manual. If you do not have them then **do not** continue the installation without them.

Preparation of the Roof

Standard Installation

Typically for cold-roof construction – the product will sit directly upon the outside of the rafters.

Sales drawings:

Installation: 202-ASS-002

Fixing dimensions: 202-ASS-001

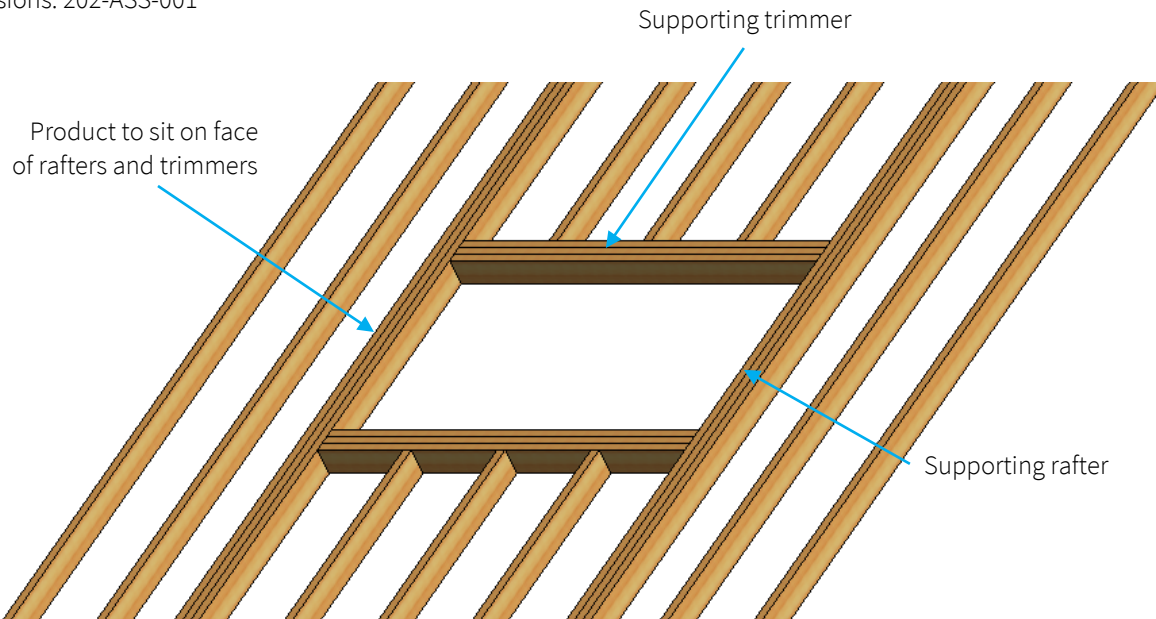

Figure A – Example of standard installation

When preparing rafters, consider how the ends of the battens will be supported at the jambs of the product. Study the sales drawings of the product carefully when designing the size of the aperture. Figure A is for illustrative purposes only and may not be suitable for your installation.



These products can be very heavy. Glazing Vision strongly recommends that a structural engineer is consulted when designing the structure(s) that will support the product and the surrounding roof. Nothing in this manual constitutes a structural proposal.

Before continuing onto the installation instructions:



The rafters and horizontal trimmers that will support the product **should** be complete and in place.



The surrounding roof **should not** yet be felted or battened, this will be covered in the installation instructions.

Preparation of the Roof – Sunken Installation

Typically for cold-roof construction with thin roofing materials, such as slate – the product will sit on the outside of a separate frame sunken below the outside level of the rafters.

Sales drawings:

Installation: 202-ASS-003

Fixing dimensions: 202-ASS-001

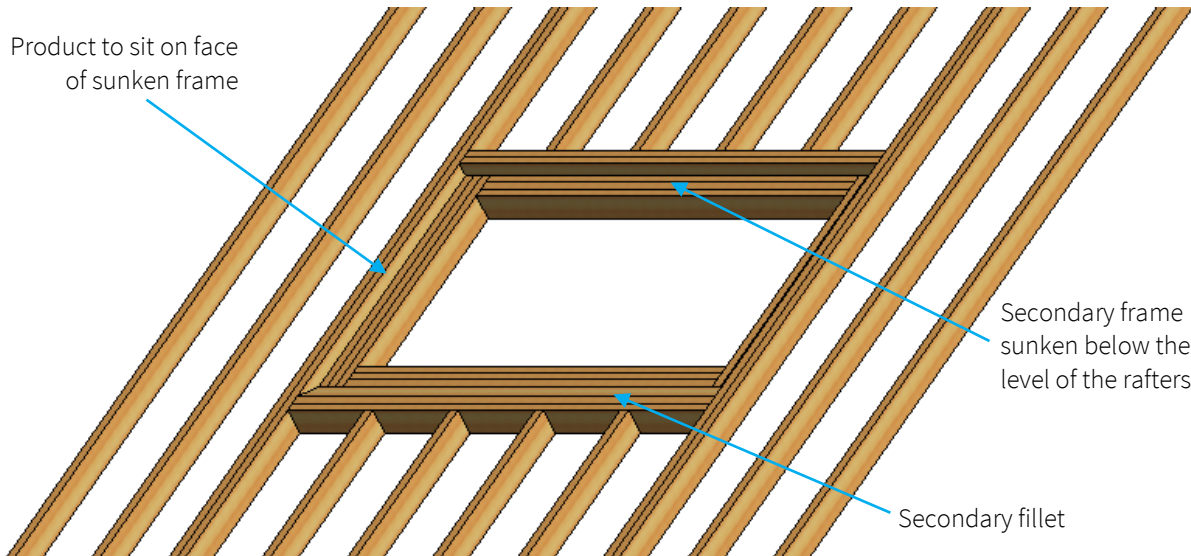

Figure B – Example of sunken installation

Study the sales drawings of the product carefully when designing the size of the main aperture and secondary sunken frame. Figure B is for illustrative purposes only and may not be suitable for your installation.



These products can be very heavy. Glazing Vision strongly recommends that a structural engineer is consulted when designing the structure(s) that will support the product and the surrounding roof. Nothing in this manual constitutes a structural proposal.

Before continuing onto the installation instructions:



The sunken frame that will support the product, and the surrounding rafters and horizontal trimmers, **should** be complete and in place.



The surrounding roof **should not** yet be felted or battened, this will be covered in the installation instructions.

Preparation of the Roof – Raised Installation

Typically for warm-roof construction – the product will sit on a frame built up from the rafters.

Sales drawings:

Installation: 202-ASS-004

Fixing dimensions: 202-ASS-001

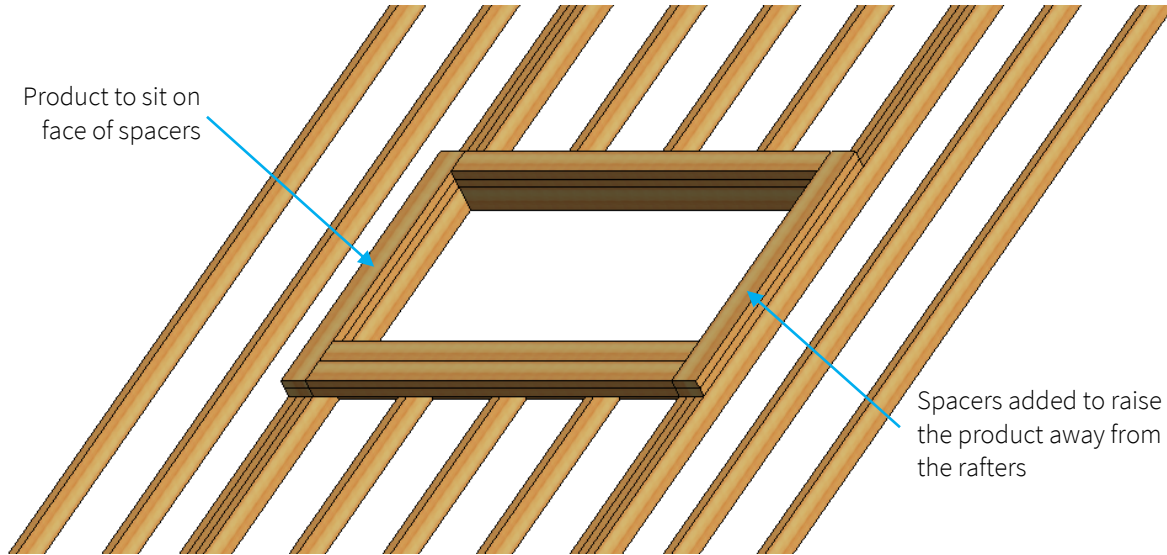

Figure C – Example of raised installation

When preparing rafters, consider how the insulating sheathing and the ends of the battens will be supported at the jambs of the product. Study the sales drawings of the Product carefully when designing the size of the aperture and spacers. Figure C is for illustrative purposes only and may not be suitable for your installation.



These products can be very heavy. Glazing Vision strongly recommends that a structural engineer is consulted when designing the structure(s) that will support the product and the surrounding roof. Nothing in this manual constitutes a structural proposal.

Before continuing onto the installation instructions:



The raised frame that will support the product, and the surrounding rafters and horizontal trimmers, **should** be complete and in place.



The insulating sheathing (the insulation installed outside the rafters) and the counter-battens of the surrounding roof **should** be complete and in place.



The surrounding roof **should not** yet be felted or battened, this will be covered in the installation instructions.

Installation Procedure

Note that the installation shown here is a standard installation, using tiles at 4-3/4” gauge. Other installations differ superficially, but the installation process is similar. All of the images in this guide are diagrammatic. They should be used as a reference only and may not be a true representation of your installation. Please refer to Glazing Vision’s sales drawings throughout the installation.

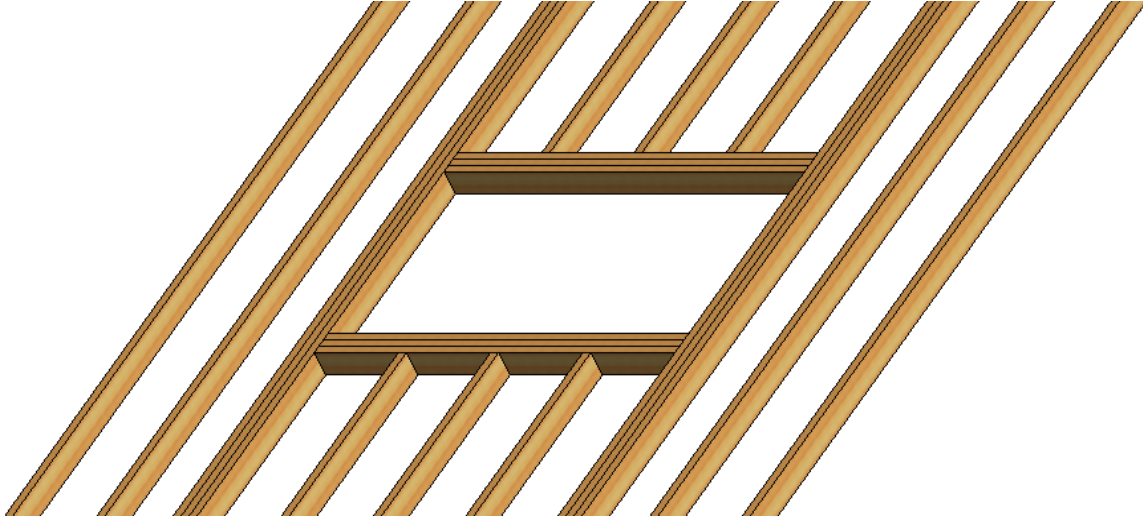

Figure D – Example of standard installation (duplication of figure A)



Ensure that you have **read and understood** the entire installation instructions section **before** starting.



The surrounding roof **should not** yet be felted or battened, this will be covered in the installation instructions.



Prior to commencing installation, **photographs of the fully weathered supporting structure and surrounding area** must be taken and retained for future reference.

Step 1 – Install, Trim and Finish the Roofing Underlay (Felt or Membrane)

Trim and then fold the underlay back on itself as shown. The underlay should be folded back on the structure that will support the product. If desired, a layer of silicone can be used to seal the cut edge down.

If a sunken installation is used, the secondary fillet (not supplied) should be underneath the underlay.

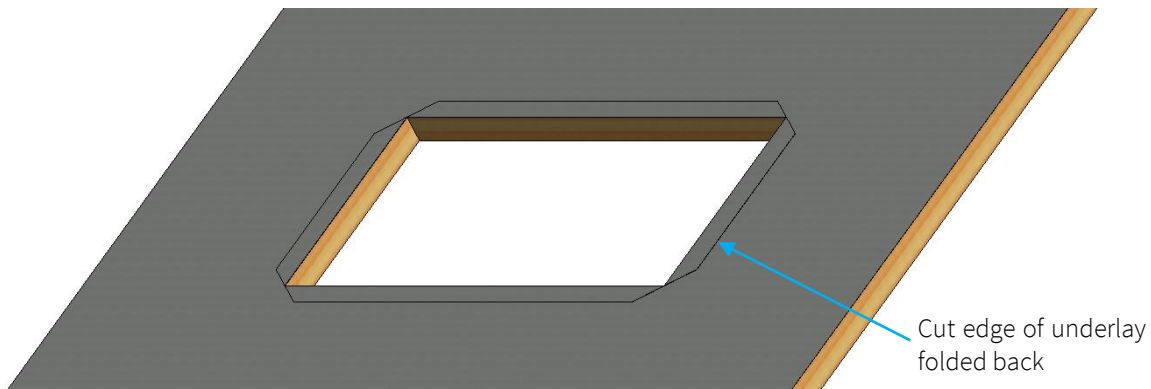

Figure 1 – Roofing underlay installed and prepared

Step 2 – Install the Sill Tilting Fillet

Install a tilting fillet as shown (not supplied) - Glazing Vision recommends that a hardwood or treated softwood fillet is used. The sill tilting fillet should be at least the length of the external width of the product and have a minimum 5° fall over the fillet. Consider the distance required between the sill of the product and the fillet (figure 2 – gap A), and also the height of the fillet. Fix the fillet to the rafters.

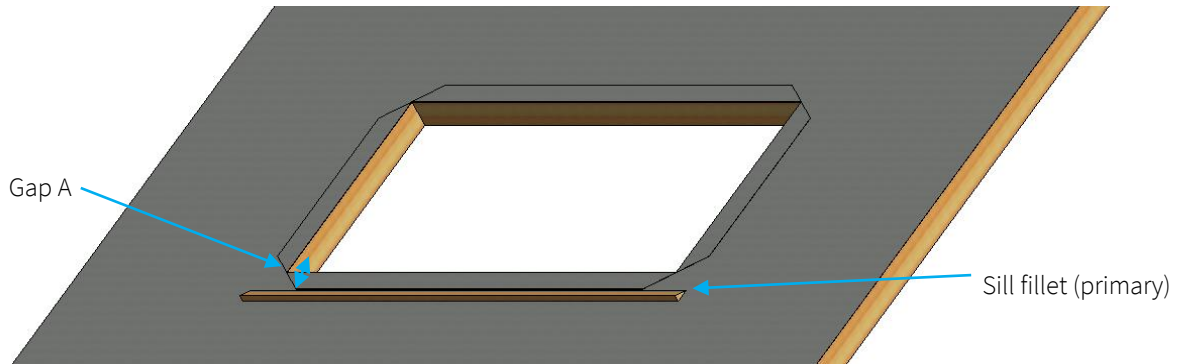

Figure 2 – Sill tilting fillet installed



The purpose of the tilting fillet is to support the flashing at the sill of the product. Lead used for flashing must be supported or it will sag over time, allowing water to pool or even to run underneath the tiling to the sides of the product.

Step 3 – Prepare and Install the Sill Flashing

Using either the sill flashing supplied as part of the flashing kit (if specified), otherwise use 0.042” thick flashing lead, fit the sill flashing. The flashing should be at least 11-3/4” longer than the external width of the product and should be installed centrally. For sunken installations the lead should extend beyond the sunken detail on either side, dressing it neatly up and over the step. The flashing should lap under the sill of the product by at least 2” but should not overlap the butyl tape to be applied in step 4. Apply silicone underneath the flashing, and if required fix the flashing in place using brass or stainless steel tacks (not supplied).

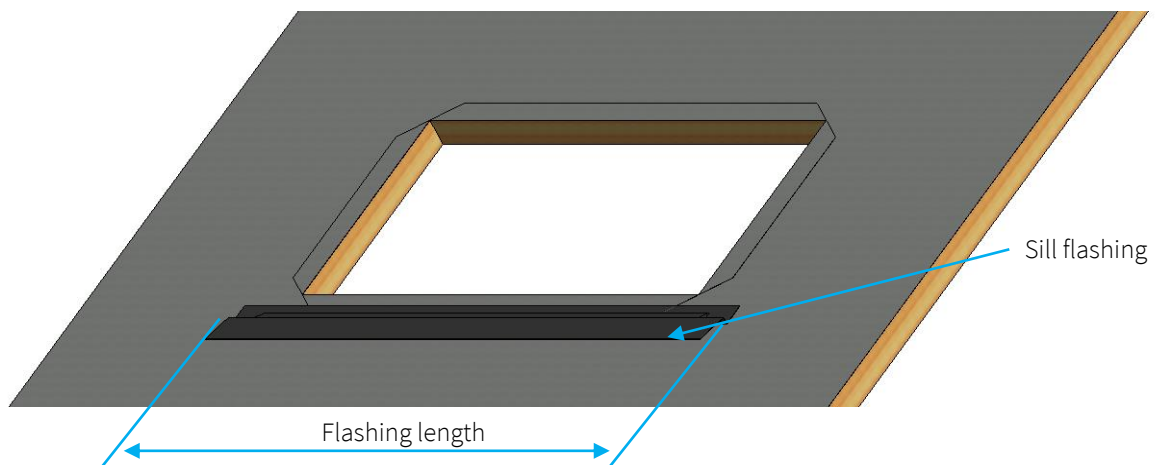

Figure 3a – Sill flashing in position

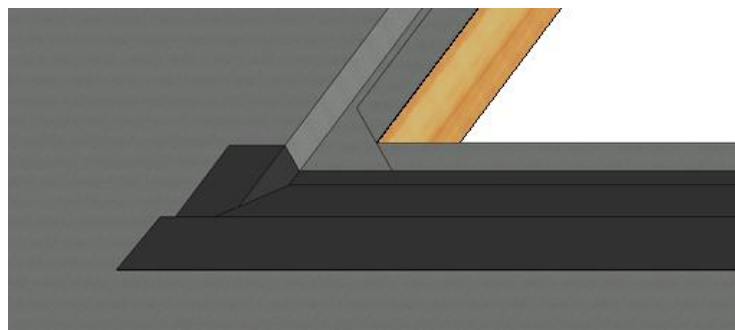

Figure 3b – Sill flashing detail for a sunken installation

Step 4 – Place and Fix the Product in Position



These products can be very heavy. Due consideration should be given to getting the product onto the roof safely and extreme care taken during installation.



Glazing Vision supplies woodscrews with the Pitchvent. If fixing to a support structure made from a material other than timber, ensure the correct type of screws or fixings have been sourced prior to commencing this step.



Before attempting to lift the product, please check that the yellow transport plate(s) are securely attached to the product.

Remove all packaging from the product including polyfoam glass protection and low tack tape.



When removing the packaging, try to keep it intact as much as possible, so that after installation it can be re-used to protect the product until project completion and final handover.

Using masking tape, tape the plastic packers (supplied) along the jambs and sill, ensuring that the product will sit centrally in the aperture – there should be a nominal 3/8” gap on all sides (filled with packers). Ensure that these will not conflict with the fixing holes in the product.

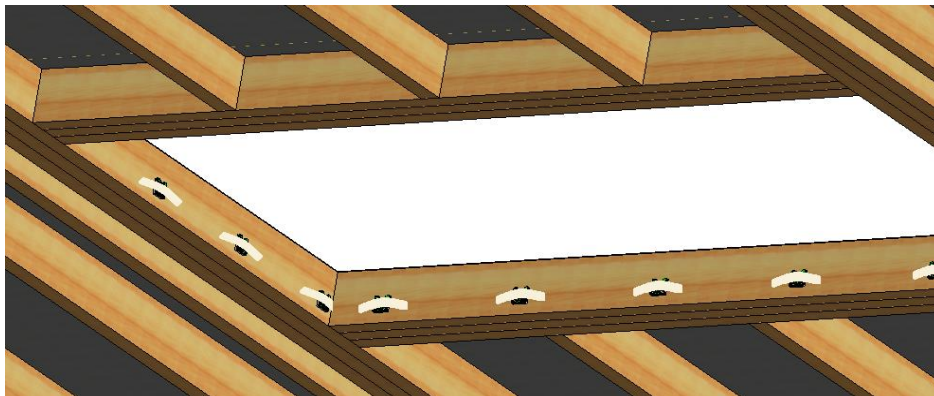

Figure 4a – Tape plastic packers along jambs and sill

Apply a continuous line of silicone (supplied) onto the underlay approximately 2-1/2” from the internal aperture.

Apply a continuous loop of 1/4” diameter butyl (supplied) to the underside of the product.

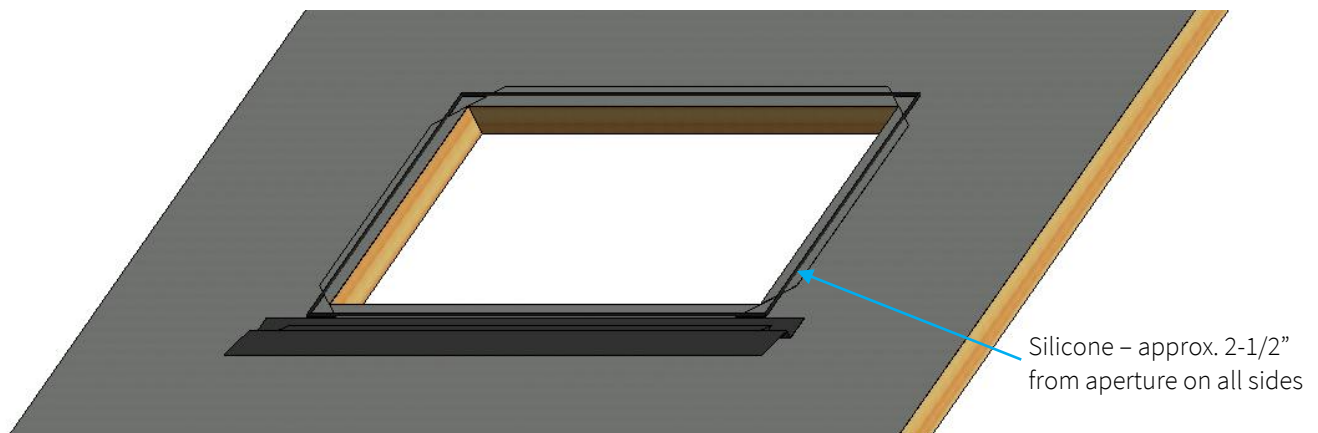

Figure 4b – Continuous silicone bead on top of underlay

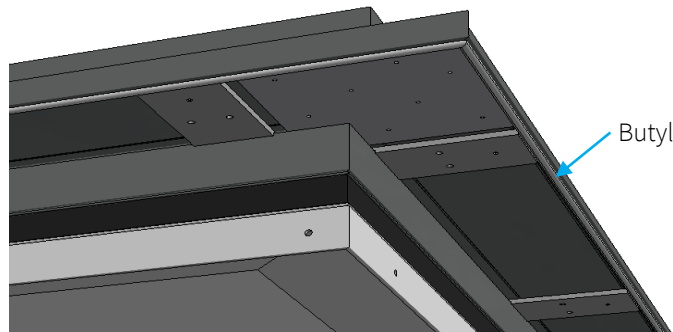

Figure 4c – Continuous butyl loop on the underside of the product

Fit the chosen lifting equipment to the unit and check that it is secure.

Carefully lift the product to the installation site (roof) using straps underneath the wooden build frame/bocks. This is to ensure that the build frame/blocks do not separate from the product during the lift.

When on the roof the product should be lifted off the wooden build frame/blocks (remove the fixings first) and then gently lowered onto the supporting structure ensuring that the cables are not kinked or snagged under the framework.

With the framework in contact with the supporting structure top and the majority of the weight still supported by the crane/lifting equipment, adjust the position of the product on the supporting structure so that the internal framework is equally spaced and aligned with the internal finishes. Take care when positioning the product during final installation, as **once the weight of the unit has been placed onto the sealants it adheres to the supporting structure making repositioning difficult.**

Once satisfied that everything is correctly positioned, carefully release the weight of the product. Remove the crane and lifting equipment.

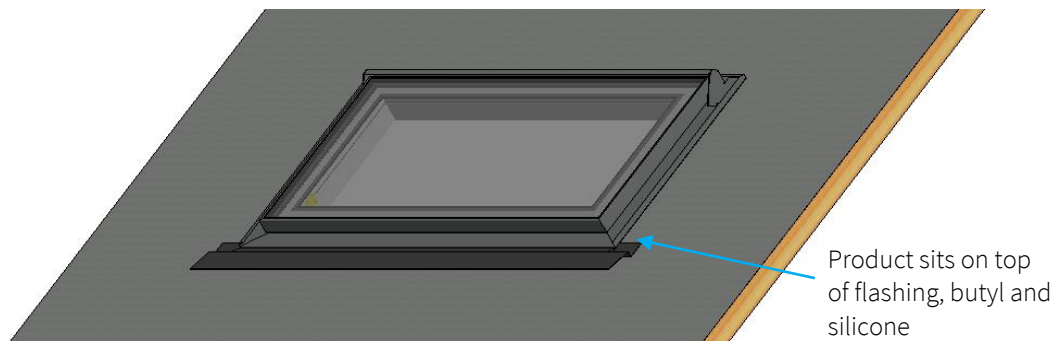

Figure 4d – Place product centrally into aperture

Working inside the building, drill Ø1/8” pilot holes into the supporting structure through the pre-drilled holes in the product’s framework. Secure the product to the supporting structure using the woodscrews and packers provided in the hardware kit. The packers must fill the entire gap between the supporting structure and product for each woodscrew. Care should be taken when tightening the fixings to ensure the frame does not distort.

Position the packers as needed, to ensure that the product is centrally positioned, fix the product into place using the appropriate fixings (woodscrews supplied).



If performing a dry run, screws through some of the fixing holes into the rafters can be used to temporarily hold the product in place. The position of the product can be marked, and the product removed. The installation can then be started.



If installing into an alternative material to wood, it may be necessary to source suitable wall plugs and/or fixings to use instead of those provided.

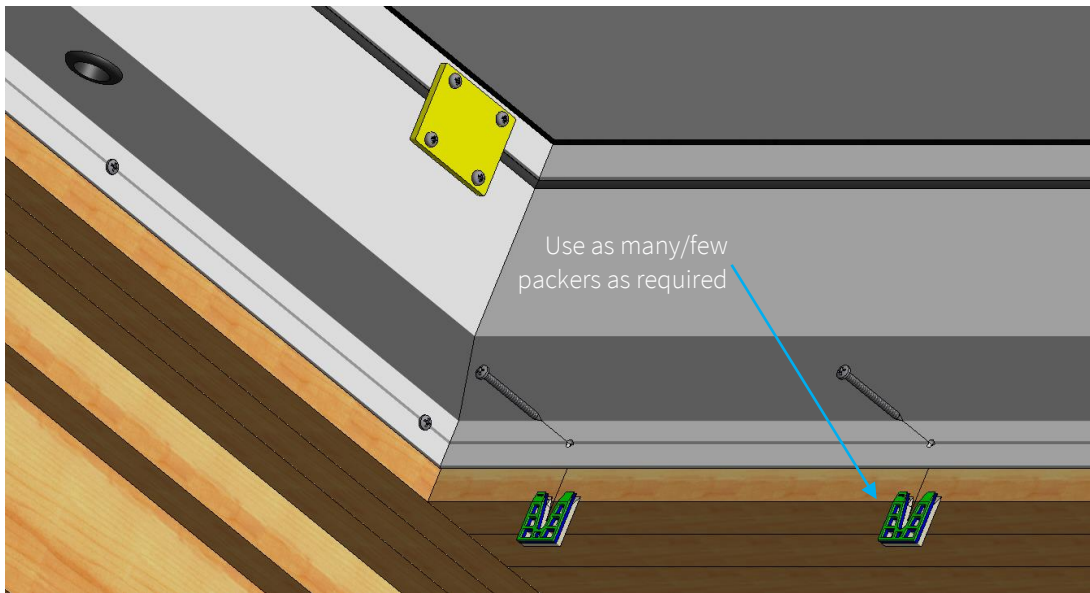

Figure 4e – Fixing detail (from inside)

Step 5 – Silicone the Head, Sill and Jambs

Run a continuous thick fillet of silicone (supplied) along the entire length of the head, the sill and both jambs.

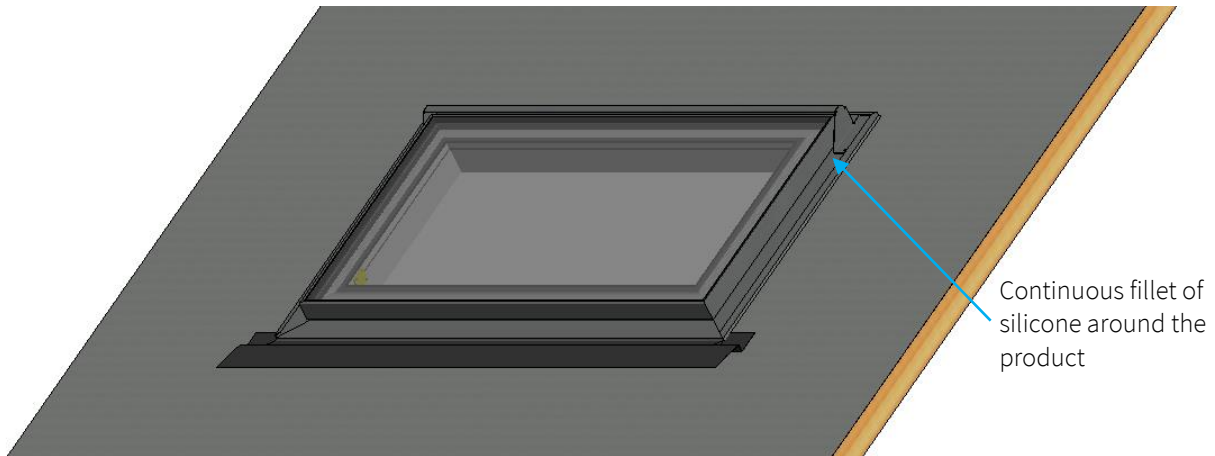

Figure 5 – Head, sill and jambs siliconed



Whilst still wet, excess silicone can be cleaned from the product by spraying on a small amount of soapy water and wiping with a cloth or paper towel.

Step 6 – Apply the Butyl Tape to the Jamb

Apply 2" butyl tape (supplied as part of flashing kit if specified, otherwise use approx. 1/16" double-sided butyl tape) to the full length of the gutter lip on both jambs (sides).

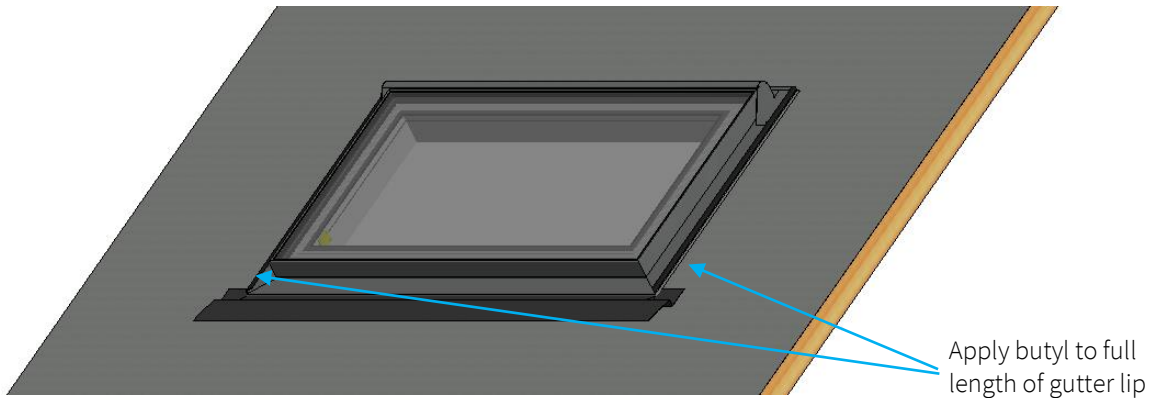

Figure 6a – Butyl tape applied to jambs

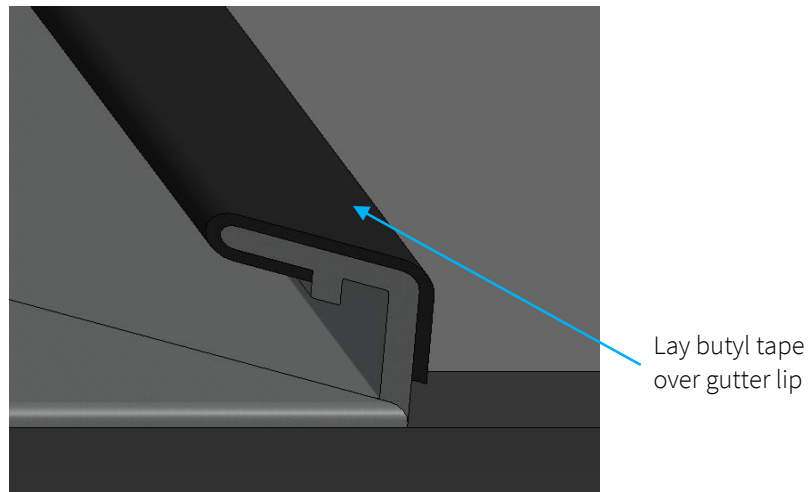

Figure 6b – Butyl tape applied to jamb

Step 7 – Place the Jamb Aprons in Position

Place the jamb aprons in position (use the roofing underlay supplied as part of the flashing kit if specified, otherwise use roofing underlay of at least 39-3/8" in width). The aprons should be at least 5-7/8" longer than the external span of the product. The bottom edge of each apron should lap over the sill flashing and should align with the bottom edge of the product sill. The aprons may be tacked in position to the rafters/counter-battens below.

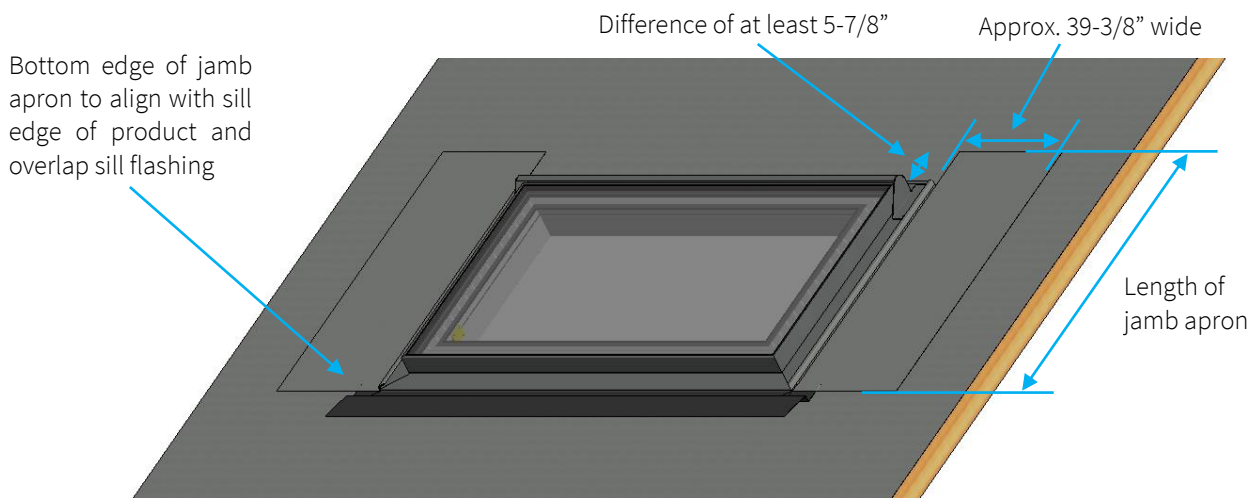

Figure 7a – Jamb aprons positioned

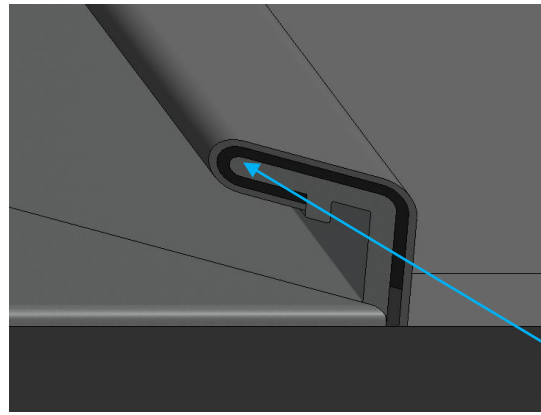

Figure 7b – Jamb apron adhered to butyl tape

Jamb apron folded around gutter lip

Step 8 – Install the Head Tilting Fillet

Install a tilting fillet as shown (not supplied) - Glazing Vision recommends that a hardwood or treated softwood fillet is used. Fix the fillet to the rafters.

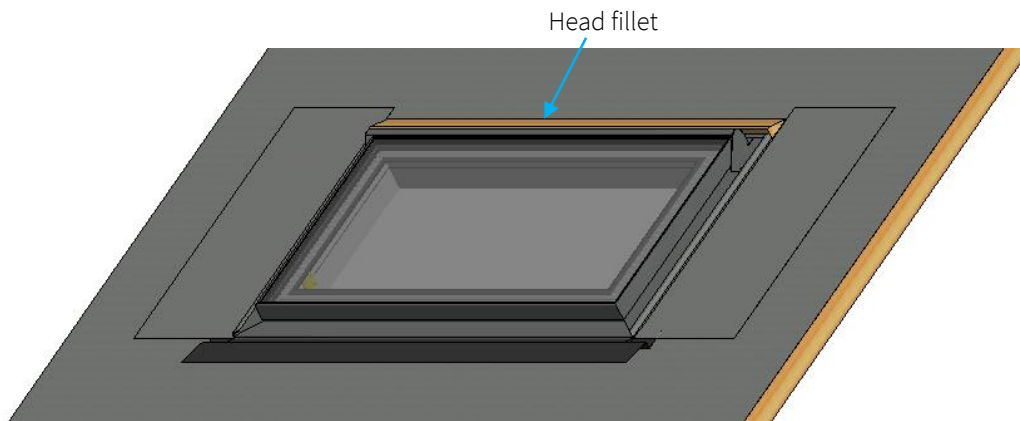

Figure 8 – Head tilting fillet installed



This product is designed for the roofing underlay to drain over the head flashing and into the head gutter of the product. The purpose of the tilting fillet is to support the apron and flashing at the head of the product. Lead used for flashing must be supported or it will sag over time, allowing water to pool or even to run underneath the tiling to the sides of the product.

Step 9 – Install the head flashing

Using either the head flashing supplied as part of the flashing kit (if specified), otherwise use 0.042” thick flashing lead, fit the head flashing. The flashing should be at least 11-3/4” longer than the external width of the product and should be installed centrally.

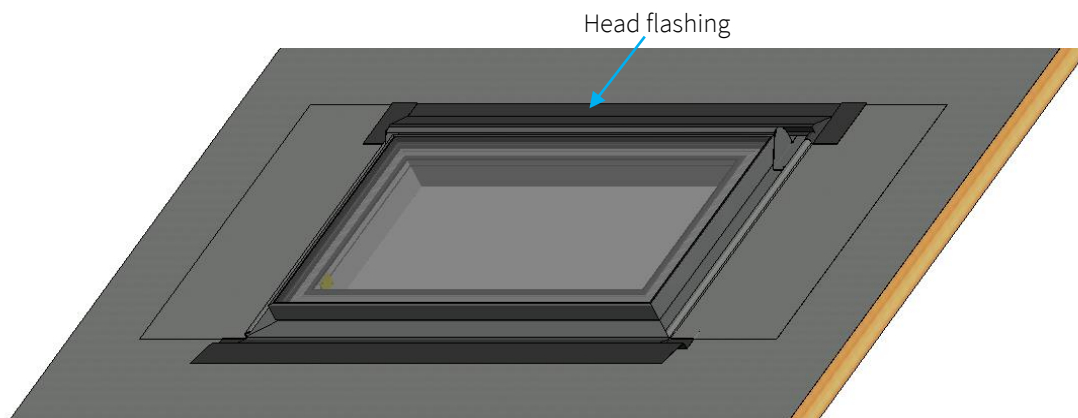

Figure 9a – Head flashing installed

Head flashing tucked into head gutter of product

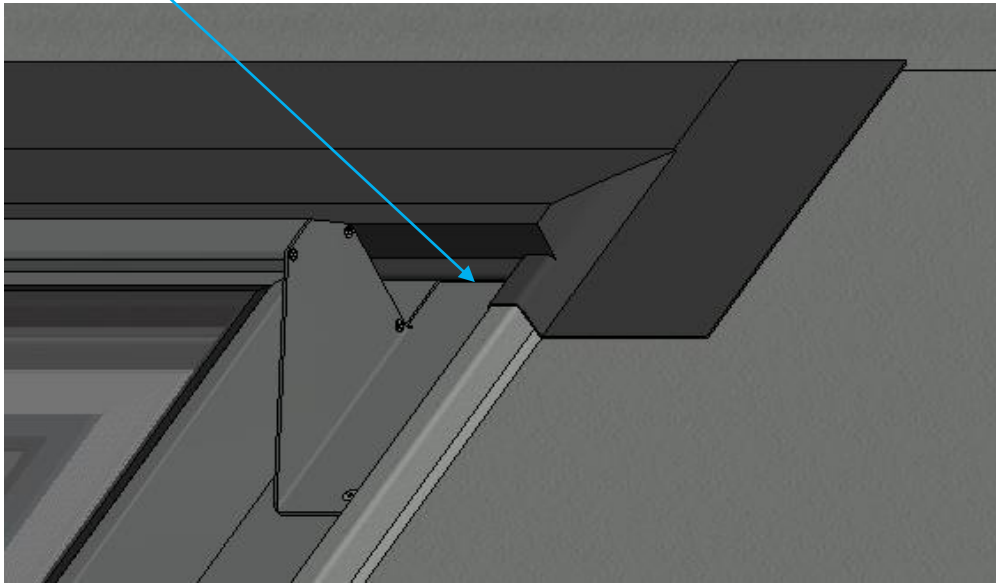

Figure 9b – Head flashing installed

Step 10 – Install the Head Apron

Place the head apron in position (use the roofing underlay supplied as part of the flashing kit if specified, otherwise use roofing underlay of at least 39-3/8” in width). The apron should cover the top of the head flashing entirely. The bottom edge of the apron should lap over the head flashing by at least 2”, and the top edge should lap under the underlay of the roof by at least 2”. If the underlay supplied/recommended does not reach, then a second piece should be used as an intermediary, lapped over the original piece and lapped under the underlay of the roof.



The head apron must be lapped into the roof underlay as described in this step. Failure to lap the apron properly may result in water ingress above the product. This lapping is also shown on the sales drawing.

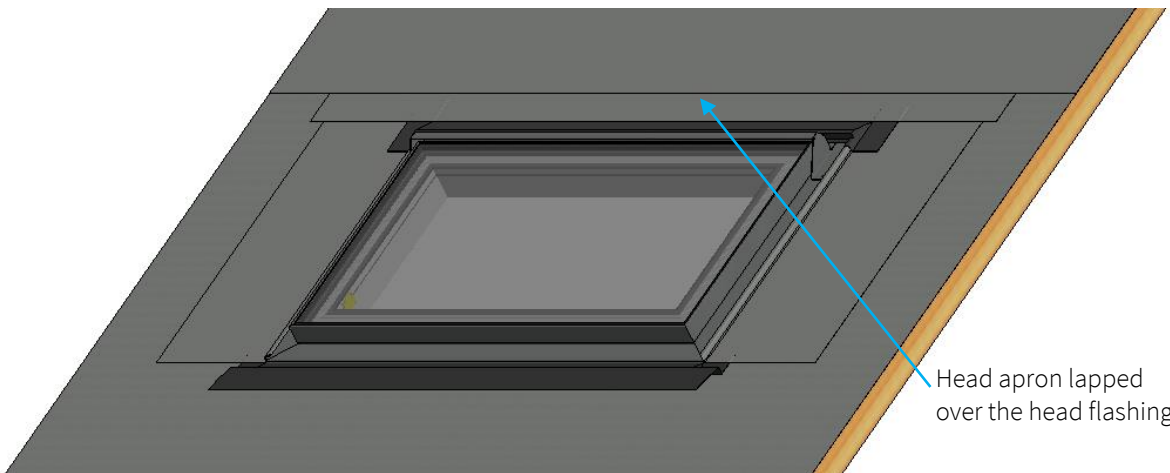

Figure 10 – Head apron installed

Step 11 – Batten the Roof

Batten up to the sill. In addition to normal considerations, consider how the tiles/slates will fit around the product when determining the gauge of the battens. The battens should be fixed in place ready for tiling/slating. Batten to either side of the product and then batten the roof above the product.

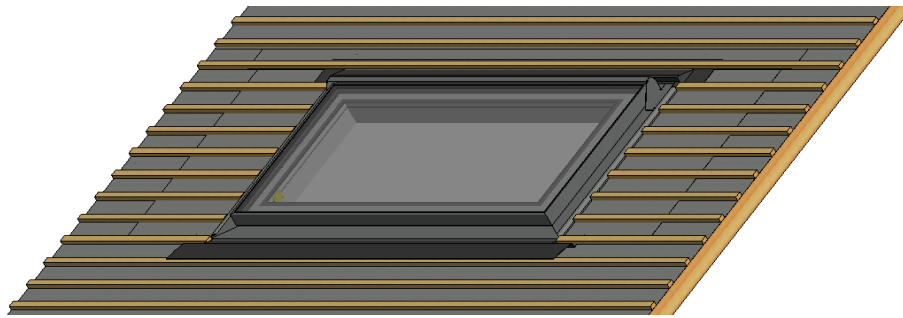

Figure 11 – Battens installed

Step 12 – Prepare the lead soakers

Using either the lead supplied as part of the flashing kit (if specified), otherwise use 0.042” thick flashing lead, fit the lead soakers. The soakers should tuck approximately 4” between the tiles/slates, should fold under the gutter of the product and should overlap by at least 2”.

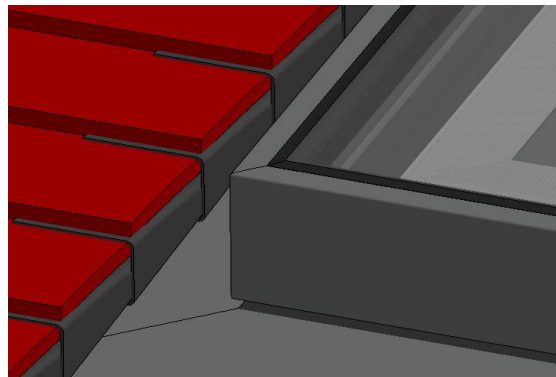

Figure 12a – Example of installed soakers

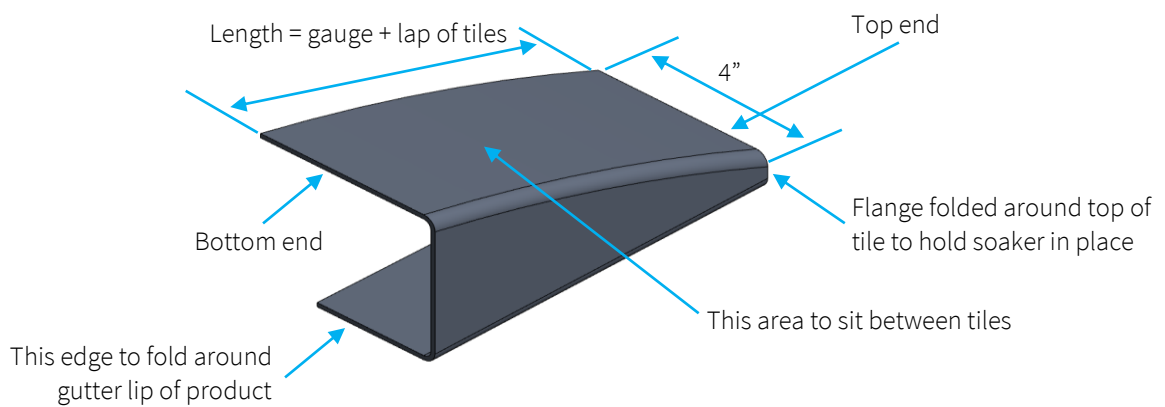

Figure 12b – Example of a soaker



Glazing Vision strongly recommends that the manufacture and installation of soakers is carried out by a competent lead-worker.



Figure 12a is presented only as an example. The soakers described in figure 12b may not be suitable for your roof.

Step 13 – Tile the Roof and Install Soakers



Before tiling, take the opportunity to check the weathering (overlap) of the aprons and flashings and to check the silicone sealing the jambs.

Tile up to the batten below the product. Fold and boss the sill flashing into final position.

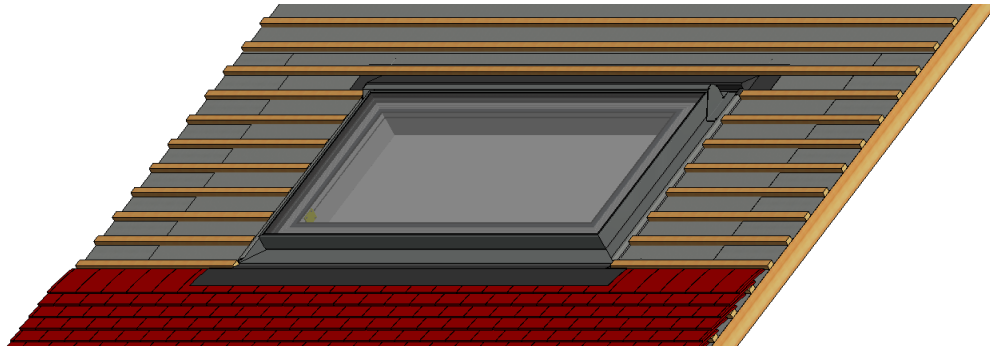

Figure 13a – Sill tiled and sill flashing finished

Tile to either side of the product, installing the soakers as you go.

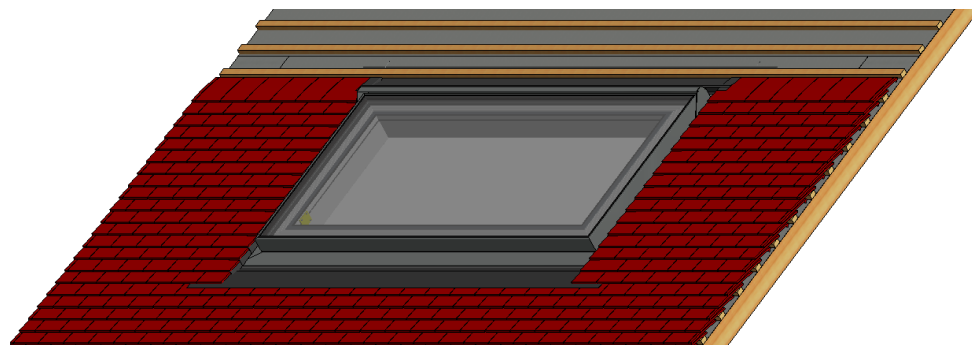

Figure 13b – Jambs tiled and soakers installed

Tile above the product. Glazing Vision recommends that eaves tiles are used immediately above.

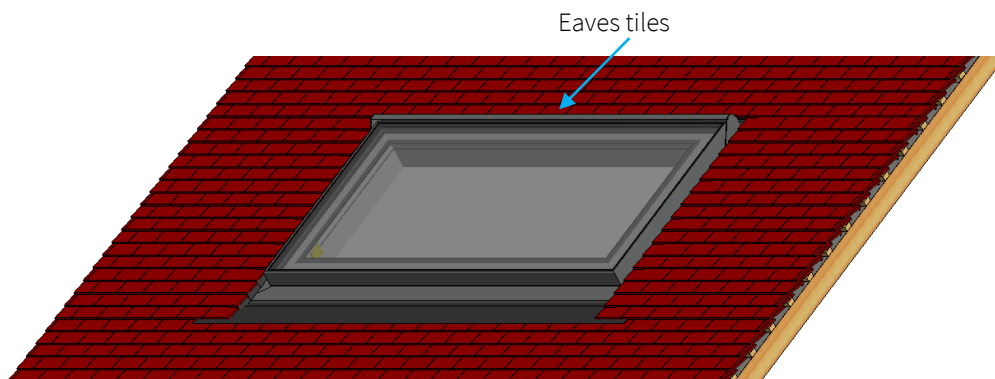

Figure 13c – Roof tiled above the head



Do not apply any interior finishes yet. Refer to the relevant following section to set up the mechanisms and initialize the product.



Once installation has been completed take **photographs of the finished installation**. These must be retained for future reference.

Chain Actuated Pitchvent Setup

Once the product has been installed, working from inside the building, remove the two yellow transportation plates (one on either side). Insert the small blanking caps (supplied) into the fixing holes for the transportation plates.

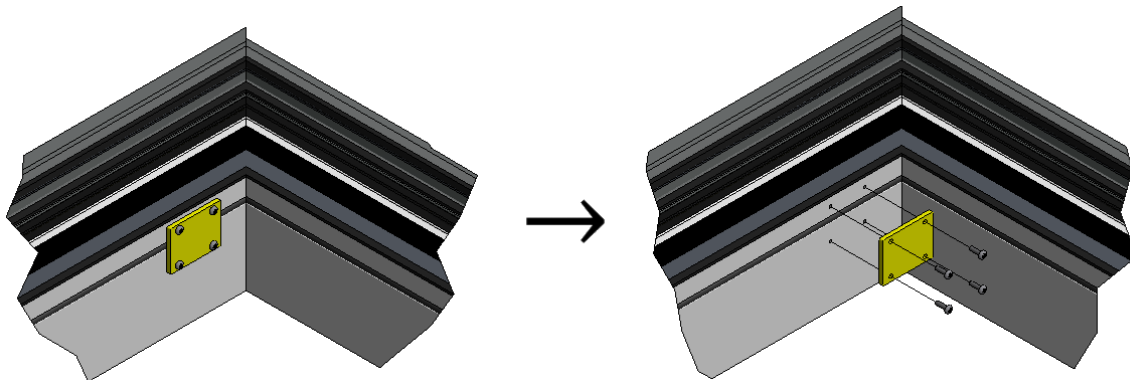

Figure 15a – Transportation brackets removed

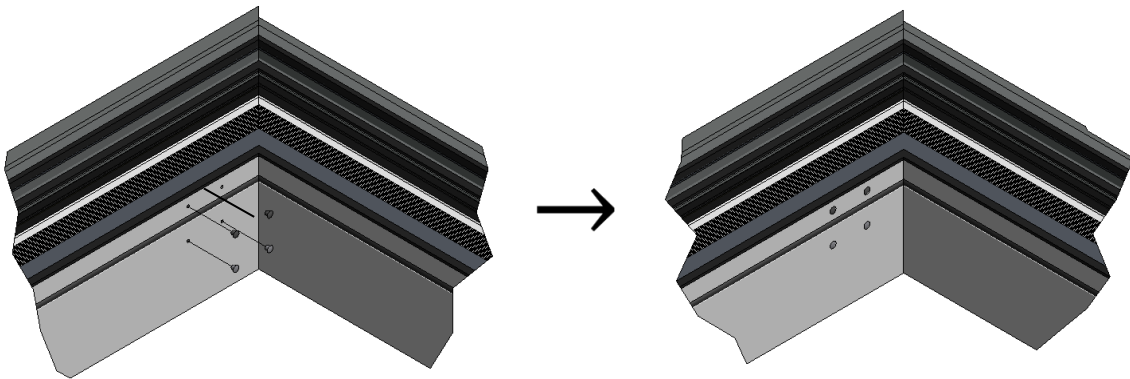

Figure 15b – Blanking caps inserted

Terminate the cables and apply power to the product following the wiring diagrams. Check that the power output from the PSU is between 24V and 26V when it reaches the product and adjust if necessary. Also install and connect any optional extras as directed (refer to Glazing Vision’s sales drawings and wiring diagrams).

Before initializing the Chain Actuated Pitchvent, first check that there are no obstructions preventing the lid from moving freely e.g. scaffolding or loads placed on the lid. Check also that the product’s mechanisms are properly engaged (i.e. the manual override procedure has not been carried out – refer to the operation and maintenance manual), failure to check this could result in mechanical damage. Switch on the power. If the product cannot be seen when standing next to the wall mounted control switch, ask for assistance before continuing. When you are ready to run the Chain Actuated Pitchvent for the first time, press the close button on the wall mounted control switch. This ensures that everything is zeroed prior to opening. The product can now be opened for the first time by pressing and holding the open button on the wall mounted control switch. When operating the product for the first time it is important to check that both chain actuators (if multiple are present) are working in tandem and the lid moves evenly. If something does not function as expected, immediately let go of the switch and contact Glazing Vision for assistance.

Manual Crank Pitchvent Setup

Once the product has been installed, working from inside the building, remove the yellow transportation plate from the sill.

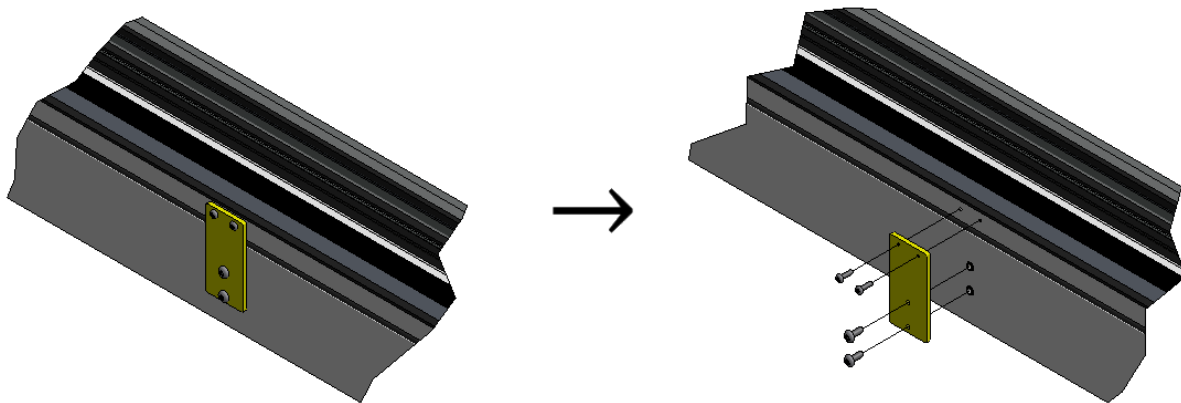

Figure 14a – Transportation bracket removed

Attach the base bracket and spacer (supplied) to the base frame of the product using the supplied screws – ensure that the bracket is correctly orientated (see figure 14e).

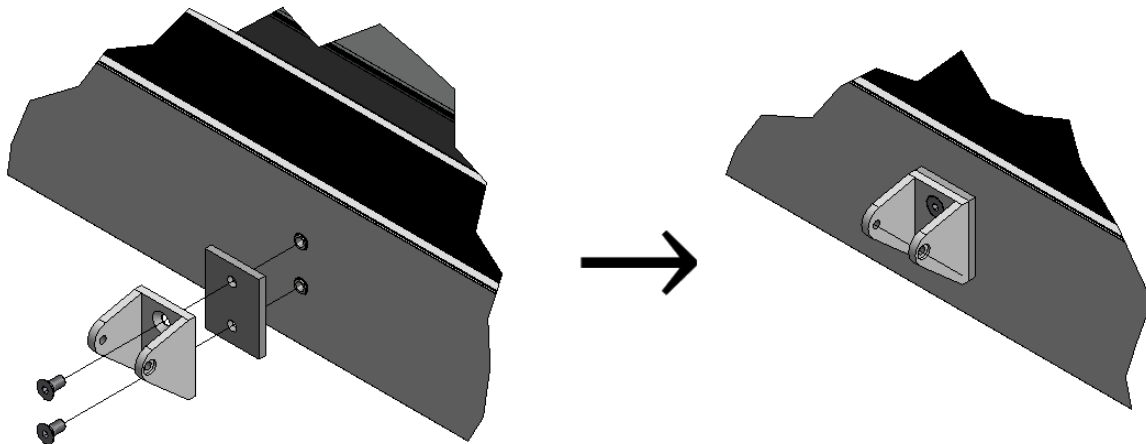

Figure 14b – Base bracket attached

Attach the lid bracket (supplied) to the lid frame of the product using the supplied screws – ensure that the bracket is correctly orientated (see figure 14f).

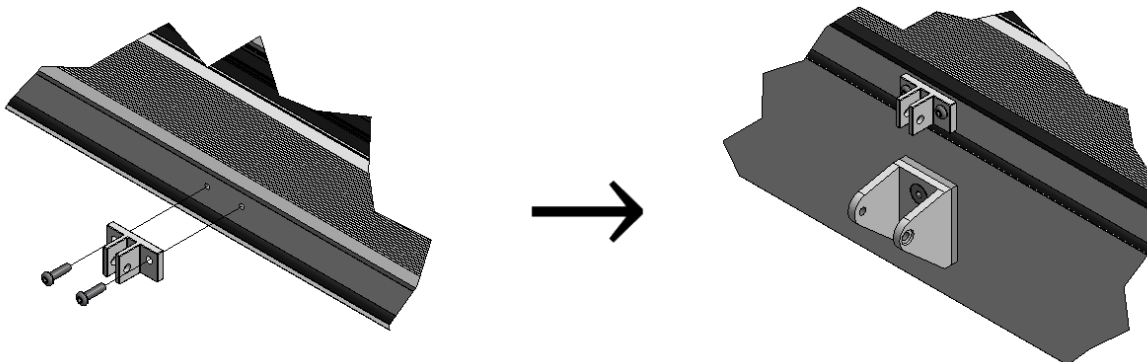

Figure 14c – Lid bracket attached

Wind the collar of the spindle all the way to the top (against the shoulder) before attaching the spindle to the frame bracket (this is essential as the glass will be in the way). Making sure that the shoulder of the spindle sits hard against the collar, unscrew a small length of the inner spindle, until it can connect to the lid bracket. Connect the inner spindle to the lid bracket using the supplied fixings.

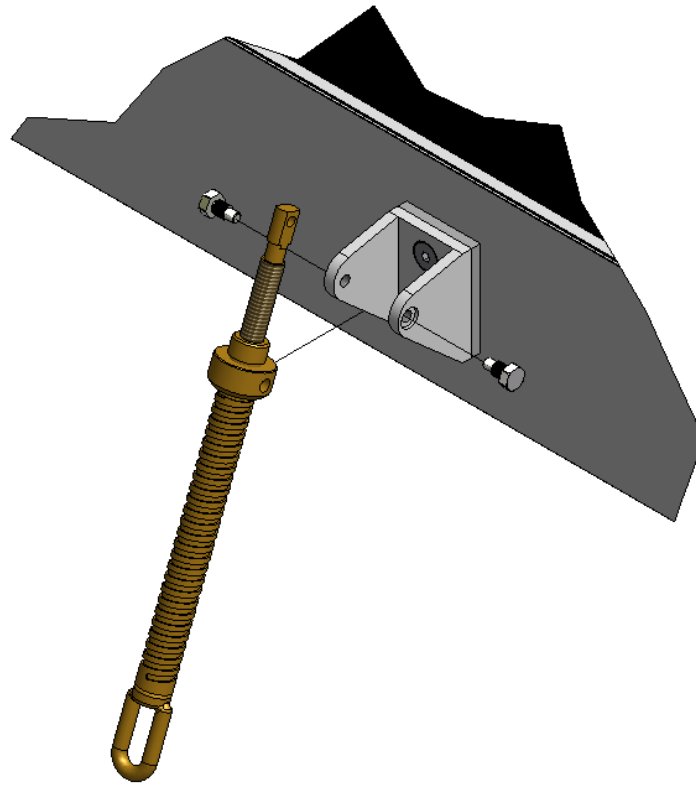

Figure 14d – Spindle connected to base bracket

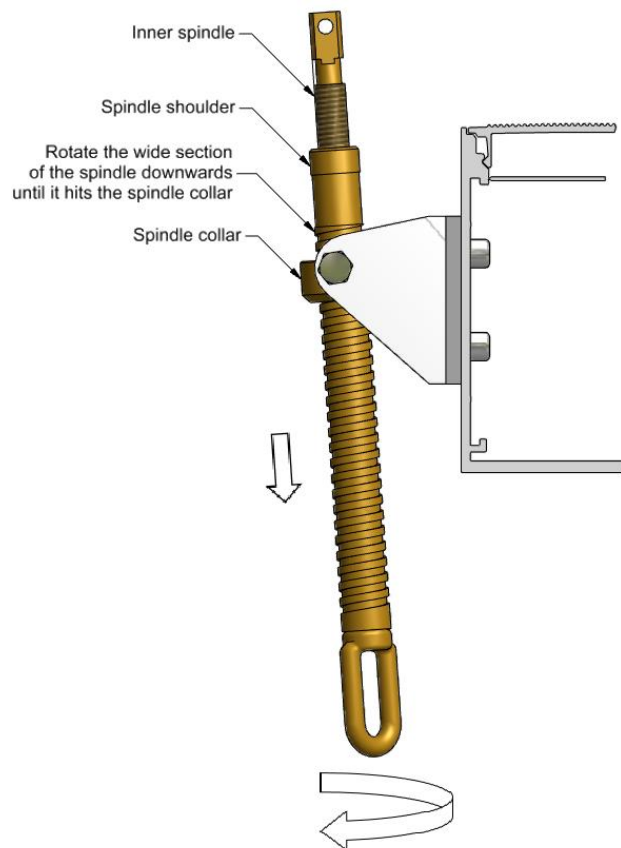

Figure 14e – Wind the spindle downwards

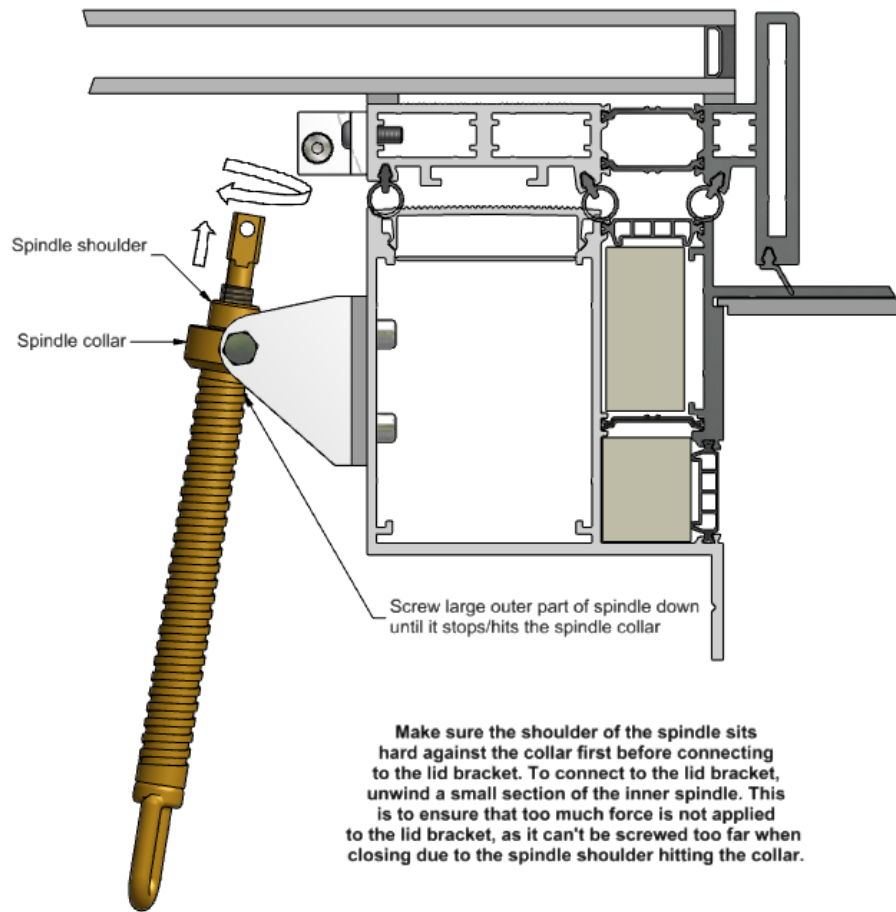

Figure 14f – Raise the inner part of the spindle

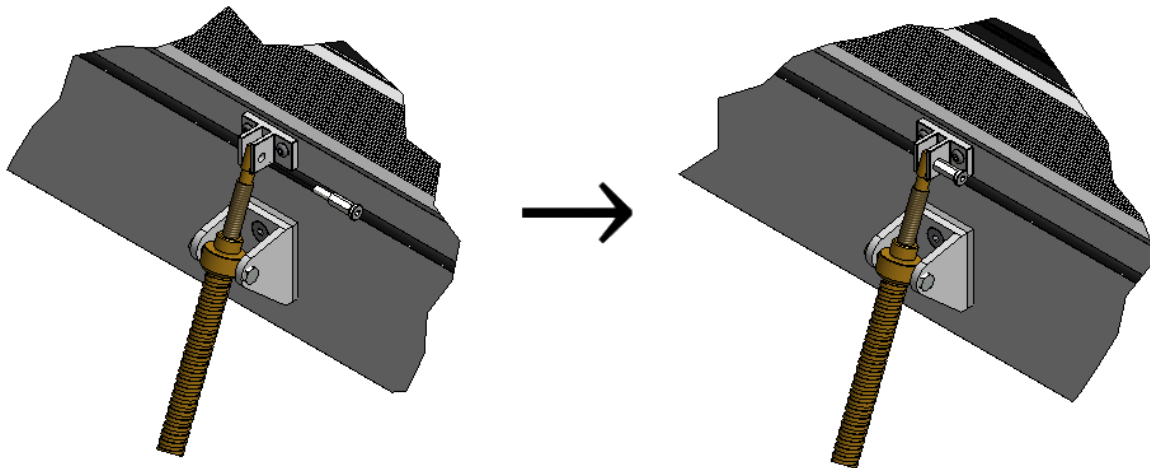

Figure 14g – Spindle attached to lid bracket

Once set up is complete, check the product. Open and close the lid to check and make sure the lid closes with the spindle reaching the end of its travel without trying to apply too much force (which may pull the bracket off the framework when winding hard down on closing).

Interior Finishing

Glazing Vision does not specify the finishes permitted except for the following stipulations:

- The finish must be built up to the internal dimension of the product – see Glazing Vision’s sales drawings.
- No interior metal component (for example edging strips for plastering) may touch any part of the product framework that is the outer color (RAL 7015 grey as standard).
- Any airspaces between the aluminum frame of the product and the internal finishes must be filled with insulating material.
- Nothing should be fixed directly to the product.
- Nothing should interfere with any mechanisms or controls present.



Contravention of any of these stipulations may severely undermine the thermal efficiency of the product.

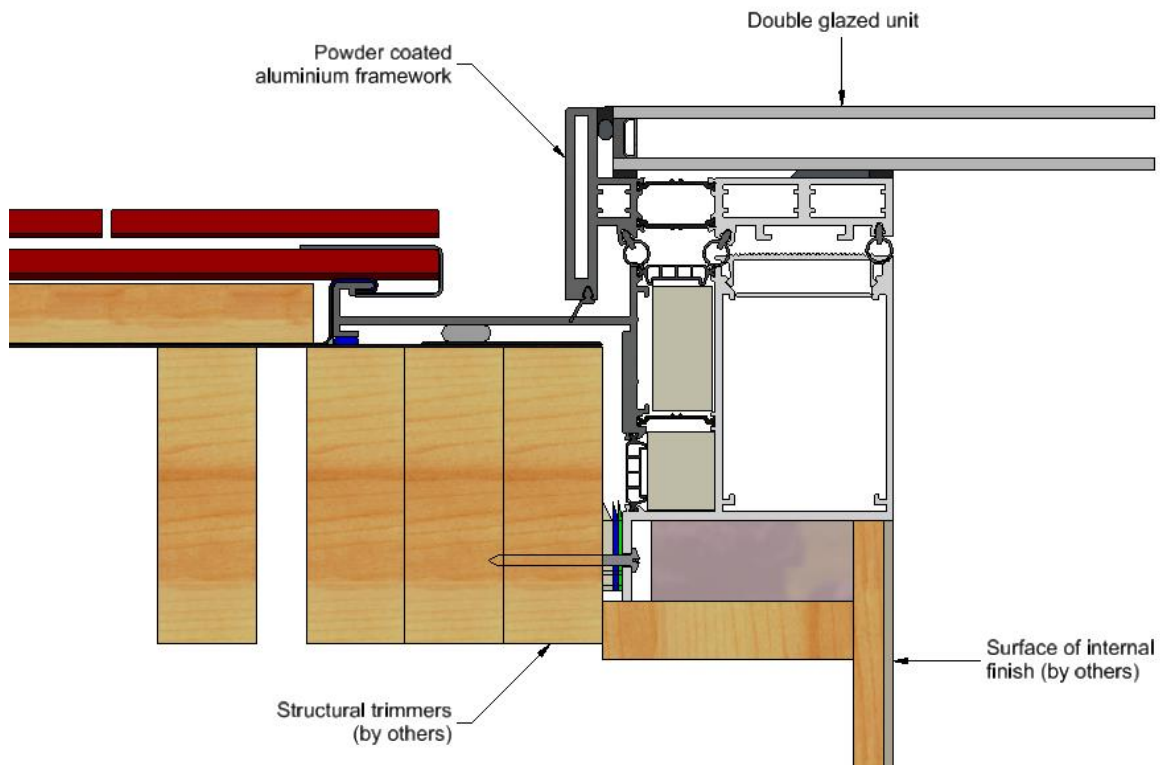

Figure E – Example section detail of a double glazed unit with standard installation